



0230-0259-E

PO BOX 4394
SANTA ROSA, CA
95402 USA

P (707) 525-9941
F (707) 575-7046
EMGPICKUPS.COM

INSTALLATION INFORMATION

EMG MODEL: PJ-HZ SET

SPECIFICATIONS

Pickup Types: Passive
Logo Color
Magnet Type
Inductance (Henries)
DC Resistance (kOhm)
Resonant Frequency (KHz) (1)
Resonant Frequency (KHz) (2)
Impedance at Resonance (kOhm) (1)
(1) Loaded with 250K Volume and Tone
and 20' (6M) 560pf cable
(2) Loaded with 1 MegOhm / 47pf

MODEL:

P-HZ	LJ-HZ
Gold	Gold
Alnico 5	Alnico 5
6.23	2.74
11.35	7.7
2.47	2.4
3.4	3.2
96.60	41.29

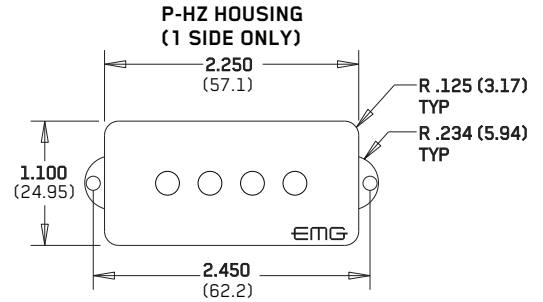

POLE PIECE LOCATIONS SHOWN
FOR SOLID-CAP MODELS

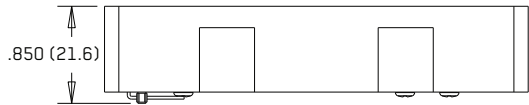
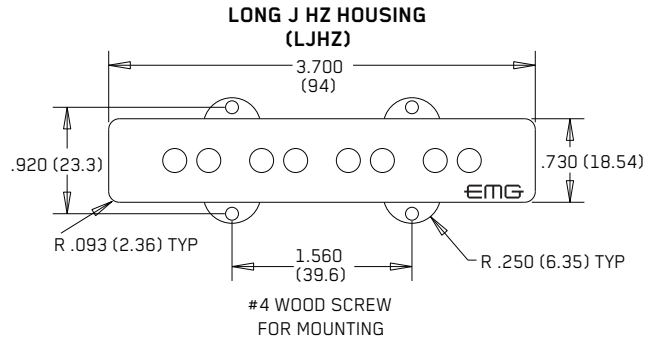

INSTALLATION NOTES:

PJ-HZ Set consists of a P Style Pickup and Long (LJ) Bridge Pickup. Both models use a side-by-side coil design for noise-reduction and feature covered Alnico 5 pole pieces for a warm, vintage tone.

EMG Active Accessory Circuits like the VLPF, EXB, BTC, or BQC Controls can be added to any EMG Pickup System and used with either passive or active pickups. Adding active circuitry will require a battery. See our website for more information: emgpickups.com

IMPORTANT NOTE: STRING GROUND (EARTH)

It is common practice to use a bridge ground wire to reduce noise in instruments with passive pickups. An IDC connector is included to attach your bridge ground wire to the EMG Ground Wire (single-ended). A "Ground Buss" and double-ended Ground Wire is used to join all common ground connections.

INCLUDED WITH THE SET:

2 VOLUME CONTROLS (250K)
1 TONE CONTROL (250K)

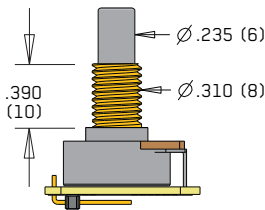

ADJUSTMENT SCREWS (8)

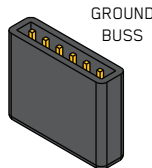
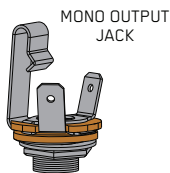
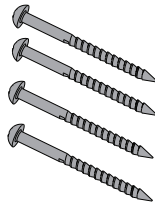

P-HZ PICKUP CABLES 13.5" (34cm) / 6" (15cm)

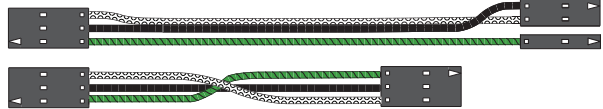

J-HZ PICKUP CABLE 9" (23cm)

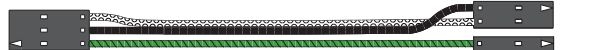

2 CONNECT CABLES 5.5" (14cm)



OUTPUT CABLE 6" (15cm)



GROUND WIRES 6" (15cm)



WARRANTY

All EMG Pickups and accessories are warranted for a period of two years. This warranty does not cover failure due to improper installation, abuse or damage. If upon examination the pickup is determined to be defective, a replacement will be made. Warranty replacement products are covered by this same warranty. This warranty covers only those pickups and accessories sold by authorized EMG Dealers. This warranty is not transferable.

Installation Instructions:

EMG Models: PJ-HZ SET

General Notes:

Every attempt has been made to make this a solderless installation.

There are some instances where this is not possible:

- 1) If your instrument uses a long panel output jack, soldering will be required
- 2) If your instrument has a selection switch or if the wiring is different, visit our website (emgpickups.com) for more diagrams and video installations.

Installation

1) Diagrams #1a and #1b show how to install the pickup cables onto the back of the pickups.

Be sure the arrows are visible as shown.

Diagram #2 shows the color code of the HZ cable, be sure to pay attention to the colors when you are installing the pickup and interconnect cables.

2) The most common method of wiring PJ Bass Pickups is using the Volume/Volume/Tone arrangement shown in Diagram #3. If your guitar is wired in the same fashion, simply follow the diagram and install the cables as shown.

Diagram #1a

Insert the plug onto the 3 pin header of the pickup as shown above. Note the orientation arrow.

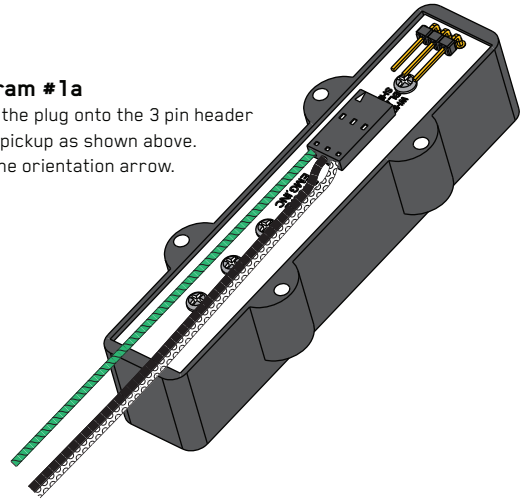

Diagram #1b

D / G SIDE

E / A SIDE

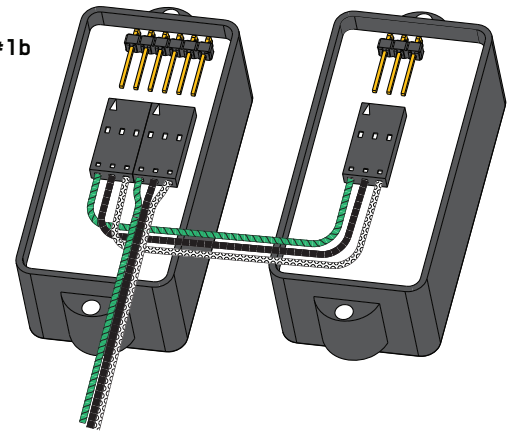

Diagram #2

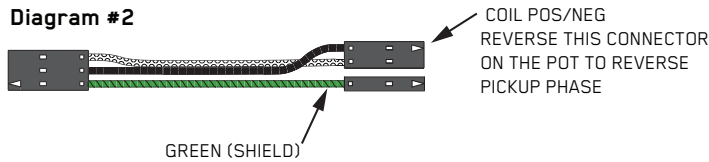
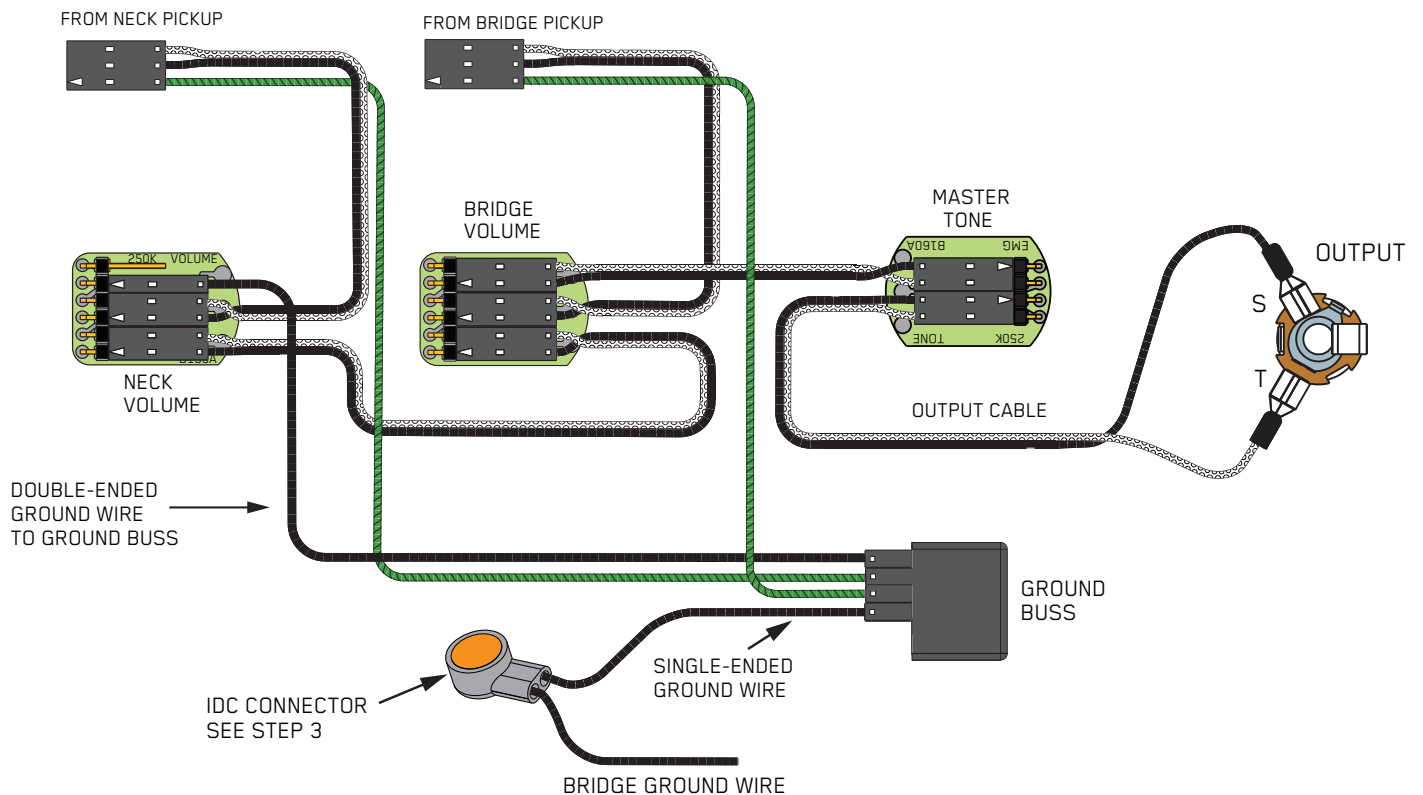

Diagram #3

2 Pickups
Volume / Volume / Tone



Attaching the bridge ground wire

3) Refer to Diagram #4.

As mentioned on Page 1, it is common to "ground" (earth) the strings on instruments with passive pickups. Included with the system is a black ground wire with a single solderless connector. Also included is an IDC connector for joining two wires together.

Insert your bridge ground wire and EMG ground wire into the IDC connector as shown. You don't need to strip the insulation from either wire. Crimp the connector with a pair of pliers until it snaps. This will connect the two wires. The IDC connector can only be used once, and cannot be "un-crimped".

Push the solderless connector into the included Ground Buss as shown in the diagram. This will ground the strings to the system.

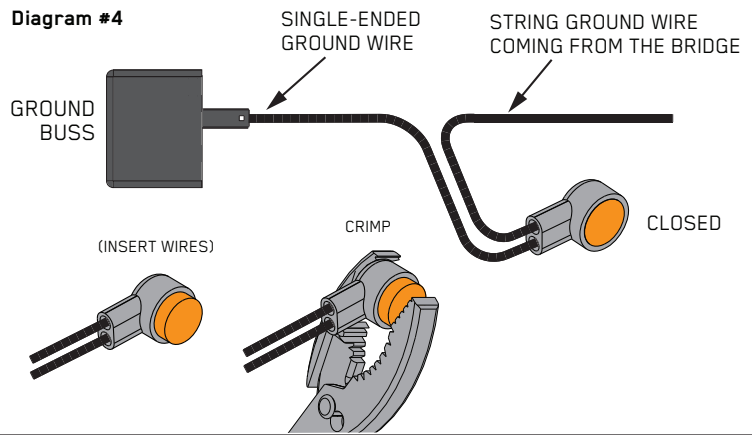

Soldering to the 151 Panel Jack:

If your instrument has a long Panel Jack like the one below you will have to solder the output cable as shown.

Ground (Black) to the Sleeve
Signal (White) to the Tip

